

# General-Purpose Technology for a General-Purpose Nervous System

Gerald E. Loeb

Alfred Mann Institute for Biomedical Engineering  
University of Southern California  
Los Angeles, CA 90089-1112  
Email: gloeb@usc.edu

Jack Wills

Information Sciences Institute  
University of Southern California  
Marina Del Rey, CA 90292  
Email: jackw@isi.edu

**Abstract**—The nervous system is a one-trick pony, using general-purpose neurons with the same basic signal transduction, transmission and integration mechanisms to handle essentially all information processing needs in the body: sensation and perception, posture and movement, autonomic and visceral function, memory and learning. Over the past fifty years, scientists and engineers have developed many different interfaces between neurons and electronic instrumentation in order to study how individual subsystems work and to fix some of them when they malfunction (e.g. pacemakers, cochlear implants, deep brain stimulators, etc.). While the various interfaces and their applications may look different, they are all based on strikingly similar, fundamental principles of biophysics, electrochemistry and information theory, and enabled by similar microfabrication and microelectronic technologies. Neural control is gradually converging on principles of design and best practices that can and should give rise to engineering standards and interchangeable components for recurring functions such as bioelectric recording and stimulation, transmission of power and data, and physical packaging and user interfaces. As such general tools become available, the clinical applications will be limited only by our understanding of the underlying pathologies, which are often best studied by those same tools. This virtuous circle consists of accessible technology enabling basic science enabling clinical applications generating business success motivating yet more technology.

## I. INTRODUCTION

After several decades of research and development, neural prosthetic implants are enjoying clinical and commercial success in a number of applications, including cochlear implants for deafness, spinal cord stimulators for chronic pain, and deep brain stimulators for Parkinson's disease. This paper reviews the scientific and technical considerations in achieving such success and extending it to more challenging applications such as brain-controlled reanimation of paralyzed limbs and restoration of functional vision. We provide an example of a novel approach to achieving a generally useful trade-off among the apparently conflicting demands for safety and efficacy in neural stimulation.

## II. SYSTEMS DESIGN CONSIDERATIONS

Most modern neural prosthetic systems employ a general architectural scheme with many or all of the components shown in Figure 1. This scheme can be divided into external and internal subsystems with means for conveying power and data between them without physically breaking the protective barrier of the skin. Each subsystem has to deal with signals that must be converted back and forth between analog and digital representations:

- Electrodes and transducers for sensory and neural command data record analog signals that must be amplified and digitized for further processing.
- Digital signal processing results in data that must be converted into modulation of a RF carrier for wireless transmission between the subsystems.
- Carrier demodulation regenerates digital representations of data and command signals that generally require substantial processing by digital algorithms.
- Command signals are converted into analog stimulation pulses delivered to electrodes.

### A. Biophysics of Neural Recording

Most neurons transmit information digitally via all-or-none action potentials that propagate along their membranes, which act like precharged, tubular capacitors. The driving voltage is about 0.1V but most of that appears across the membrane and along the fluid core of the tubular axon. The action currents in myelinated axons are of the order of 1-5nA depending on fiber diameter [1]. The extracellular potentials generated by the cell body and dendrites of a large neuron [2] or a myelinated axon decline rapidly with distance, rarely exceeding 300 $\mu$ V and declining toward background noise levels of  $\sim$ 10 $\mu$ V within 10-100 $\mu$ m. Microelectrodes small enough to locate near active neurons typically record a mixture of unitary signatures with energy in the 1-5kHz band and frequencies of 10-100pps that can be discriminated by subtle differences in amplitude and shape. There has been a lot of progress on the silicon

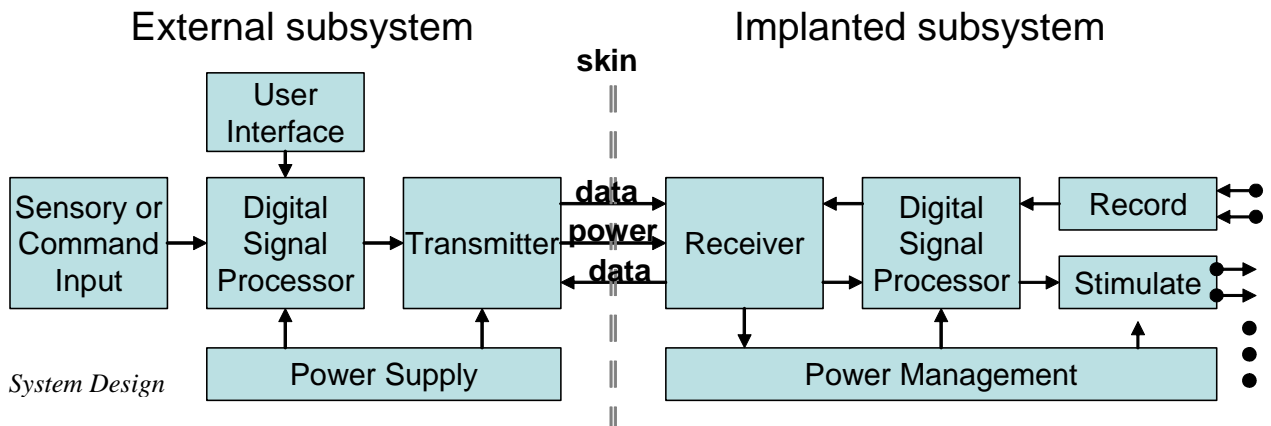

Figure 1. System Design

integration of low-noise, low-power amplifiers and high rate digitizers, signal processors and telemetry systems for implantation. Unfortunately, currently available microelectrodes tend to provoke connective tissue reactions that displace active neurons from the tip progressively over months, leading to a gradual loss of discriminable unit activity [3]. Lower frequency field potentials such as electrocorticograms and electroencephalograms are relatively easy to record chronically but they provide much less temporal or spatial information.

### B. Biophysics of Neural Stimulation

Neurons generate action potentials when their capacitive membranes are discharged to a threshold potential, usually about 15mV less negative than their usual resting potential of about -70mV. Extracellular electrodes can induce depolarizing (and hyperpolarizing) current to flow across the membrane by creating an extracellular voltage gradient ( $dV/dx$ ) in the tissue that changes over time ( $dV/dt$ ) [4]. The RC transmission-line properties of the target neurons define a space constant ( $\sim 1\text{mm}$ ) and a time constant ( $\sim 100\mu\text{s}$  for myelinated axons,  $\sim 1\text{ms}$  for cell bodies) that govern the design of efficient electrode geometries and pulse parameters. The moderate conductivity of the surrounding tissues ( $100\text{-}1000\Omega\text{cm}$ ) makes it possible to selectively stimulate small populations of neurons by their relative physical proximity to small electrodes. The strength of stimulus pulses is limited by the metal-electrolyte junction potential at which irreversible and harmful reactions occur, including corrosion of the metal and electrolysis of water [5]. Until these potentials are reached, metal electrodes tend to behave like capacitors, so the safety limit depends on charge per unit area. For example, commonly used platinum can be operated cathodally (to depolarize nearby neurons) up to a maximal charge density of  $300\mu\text{C}/\text{cm}^2$ , but only if the charge injected by each pulse is entirely neutralized by current flow in the opposite direction between pulses (see III. below). This is usually guaranteed by the incorporation of a DC-blocking capacitor in-series with each electrode.

### C. Hostile Environment of the Body

The human body consists of warm, constantly moving, salt water with a large number of dissolved proteins and lipids and circulating immunological cells bent on enzymatic and mechanical destruction of foreign materials. It is not a good place for semiconductor junctions, voltage-carrying

conductors, flexible leads or electrical connectors. These obstacles have been overcome to date by enclosing active electronics in rigid packages with hermetic seals and feedthroughs (welded metal, braised ceramic and/or melted glass) [6]. Electrodes and flexible leads to them have mostly been hand-crafted from stranded or helically coiled wire made of noble metals, mostly platinum and iridium alloys.

### D. Communication with the Outside World

Most neural prosthetic implants receive electrical energy (for immediate use or to recharge batteries) and command data by inductive coupling of RF magnetic fields generated in a transmitting coil outside the body. The same or a similar link may be used to send data out from the implant. Efficient transmission of power becomes exponentially more difficult as the dimensions of the implant shrink or the distance and alignment between external and implanted coils becomes variable [7]. Transmission of data is also problematic for small devices with many channels. The fast and efficient wireless links becoming ubiquitous in consumer electronic devices can use small antennas because they operate at frequencies  $>1\text{GHz}$ , but water becomes a progressively more efficient absorber of microwave energy at frequencies above 200MHz.

## III. CHARGE-METERED STIMULATION

### A. Motivation

Next generation neural prosthetic systems are likely to include large numbers of closely spaced channels of stimulation, ideally controlled by integrated electronic circuitry in close proximity to the electrodes. There will be no room for coupling capacitors to prevent polarization and damage of the electrodes. Most of the required electrical power will go into pushing the stimulation currents through the electrodes and tissues, whose impedance tends to rise as dimensions shrink. Inefficiencies translate into heat that must be dissipated from the electronic circuitry into the surrounding, heat-sensitive tissues.

The usual method for controlling stimulation pulses is to specify and regulate their current and duration independently. Current regulation is generally preferred to voltage regulation because the relevant potential gradient in the tissue depends on the current density through it. This should be independent of the impedance of the metal-electrolyte interface, which may

change over time. The compliance voltage of the current regulating circuitry must be high enough to avoid saturation over the whole range of possible electrode and tissue impedances and the requested current values. The difference between this supply voltage and the actual stimulus voltage across the electrodes is dissipated as heat in the driving circuitry.

### B. Design

Neurons actually respond to brief stimulus pulses as low-pass filters with the time-constants described above. This makes it possible to trade-off stimulus current and pulse duration for relatively short pulses. The effective intensity of a brief stimulus pulse is determined by its integrated charge, regardless of waveform. This is the same parameter that determines the electrochemical safety of the stimulation. If stimulus charge can be controlled directly, it is possible simultaneously to optimize both power efficiency and safety. The basic approach is to connect the electrode directly to the negative supply voltage (for cathodal stimulation) when a stimulation pulse is required and to disconnect it after the requested amount of charge has passed through it [8]. We obtain these connections using CMOS transistors operating in triode mode to act as switches. A small sensing resistance ( $R_{sn}$ ) develops a voltage proportional to the instantaneous probe current. By integrating this voltage we measure the accumulated charge. The output of the integrator is measured against the desired amount of charge by a comparator. When the comparator switches, we then connect the probe to the positive supply voltage. This reverses the direction of current flow, and acts to discharge the integrator. When the integrator voltage reaches zero, we have perfect charge balance and we stop stimulation.

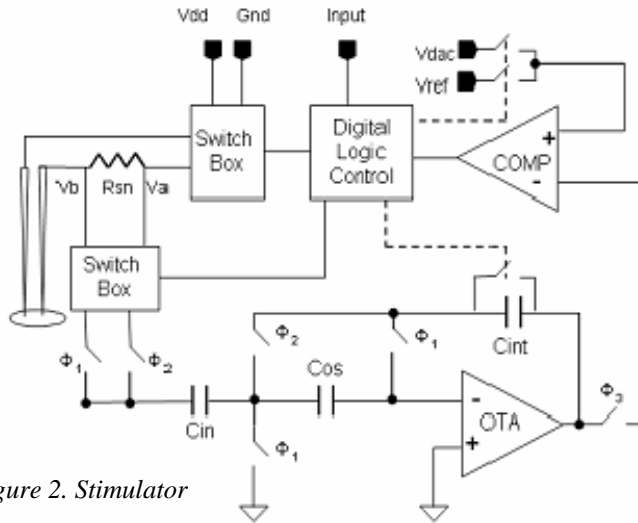

Figure 2. Stimulator

Figure 2 shows the required components of the charge metering stimulator. The OTA,  $C_{in}$ ,  $C_{os}$ , and  $C_{int}$  form a switched capacitor integrator. Stimulation effectively becomes a simple and efficient digital function that is controlled by analog sensing. Blocking capacitors are not required.

We also note the effective probe impedance is given by:

$$R = (\text{Charge Time}) * (V_{ss}) / (\text{Desired Charge})$$

By adding a simple timer to the circuit, we can measure the mean impedance of the probe for each pulse. This can be used to monitor the condition of the probe/tissue interface.

### C. Proof of Concept

The system concept was verified by constructing a board level prototype using commercially available integrated circuits. This unit was successfully tested by Dr. Jim Weiland at the Doheny Eye Institute [9]

### D. ASIC Design

We have completed an integrated design in a  $0.18\mu$  CMOS process. The integrator is a switched capacitor design using a 5MHz clock. The largest on chip capacitor is 2 pF;  $\Phi_1$  and  $\Phi_2$  are the non-overlapping clocks. These clocks are used to connect  $C_{in}$  to alternate ends of the sense resistor  $R_{sn}$ . The difference in these voltage is transferred to  $C_{int}$  which accumulates the total delivered charge. To reduce the size of  $C_{int}$  a folding method is used. Whenever the integrator voltage is greater than 1.0 Volts or less than 0.6 Volts we reset the integrator, and update a counter. This is shown in Figure 3. The top trace shows the integrator voltage, the middle trace shows the voltage at the probe tip, and the lower trace shows the delivered current. The circuit operated from 1.8 Volts and total power is less than  $50 \mu W$ . Charge error is less than 0.5% and charge imbalance at the completion of the stimulation cycle is less than 0.2%. When stimulation is completed, both probes are connected to ground to further dissipate any residual charge.

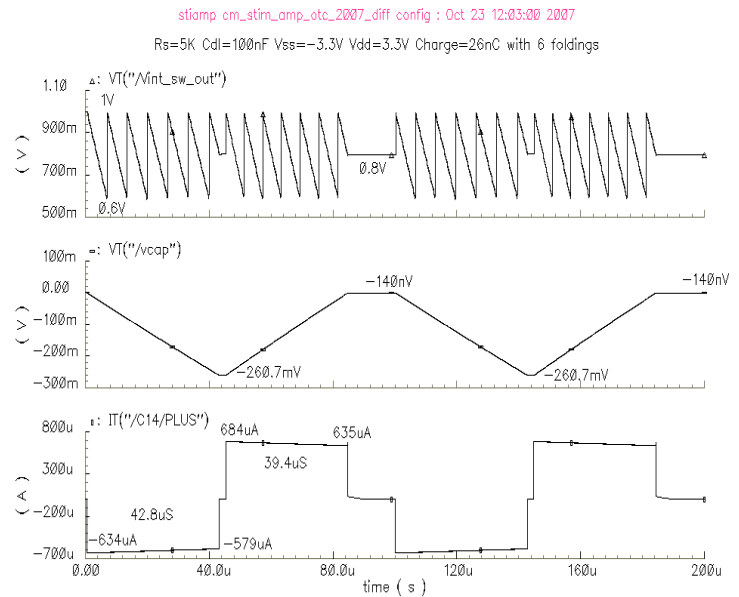

Figure 3. Simulation Results

The  $0.18\mu$  CMOS process is limited to  $V_{dd}$  of 3.3 volts, so we use off-chip switching transistors to allow higher stimulation voltages. These transistors can be placed on-chip if we use a higher voltage process such as XFAB XH035.

#### IV. OPPORTUNITIES AND CHALLENGES

As neuroscientists gradually understand better the normal and pathological functions of the nervous system, there will be ever more opportunities to use neural prostheses to treat clinical disorders. Many of these will require more sophisticated interactions between electronic and neural circuits mediated by larger numbers of more closely spaced electrodes than are now feasible. This is motivating development in the following auxiliary technologies:

##### A. *Biocompatible Interfaces*

The materials that directly contact the targeted neural tissues are really “biotolerated” rather than “biocompatible” [10]. Rather than being recognized as neural tissue themselves, they are identified as nontoxic foreign matter that the body walls off with a relatively thin layer of non-reactive scar tissue. In so doing, however, the electrodes are displaced from the target neurons by a distance that may preclude recording or stimulation of individual neurons. Ideally, the surfaces of the electrode arrays should present attractive and stable substrates for these neurons. The cell adhesion molecules that encourage and maintain such connections between neurons are starting to be identified. They are mostly polypeptides, however, that persist on cell surfaces only because they are constantly resynthesized by the cells, a feat not yet within sight for man-made materials.

##### B. *Integrated Packaging and Electrodes*

The current methods for rigid hermetic packaging of active electronic circuits are incompatible with the numbers of electrodes that will be needed in the future. Methods must be developed to integrate stimulation and recording circuitry directly with electrode arrays. In many applications, the interfaces themselves or connections between them must be mechanically flexible. Polymeric substrates and encapsulants such as Parylene, Teflon, liquid crystal polymers, thin silicon and diamond films have been employed, but none has yet demonstrated the required combination of near-zero permeability, high adhesion, biostability and mechanical toughness for long-term use in the body.

##### C. *Indigenous Power*

Integrated microelectronic systems are starting to approach the dimensions of neural circuitry, suggesting that free-standing modules might be injected into the target structures. One large obstacle to this approach is the need for replenishable electrical energy. As the implants get smaller, the ability to transfer energy to them by inductive coupling or photovoltaic conversion drops precipitously. In theory, these modules could derive power just as neurons do, utilizing the constant supply of glucose and oxygen provided via the circulatory system. Fuel cell and enzymatic conversion have some promise but must resist biodegradation and biofouling for long-term use. The peak power required for currently available methods of stimulating neurons and communicating with the outside world is substantially higher than the metabolic capacity of neurons but the duty cycle may be low enough in some applications to permit temporary storage of locally scavenged energy.

##### D. *Adaptive Control*

The central nervous systems spends the first few years of its life doing tasks related to system identification and self-organization; it then spends the rest of its life adapting to growth, plasticity and gradual decline of all the end-organs with which it interacts. A sophisticated neural prosthesis introduced into such a mature and evolving system must provide useful and reliable function without posing an undue burden on the therapists, who must adjust its many parameters initially, or the user, who must learn to overcome its inevitable shortcomings. Much of the delay in widespread acceptance of the present multichannel neural prostheses (e.g. cochlear implants and spinal cord stimulators) has been related to providing intelligent user interfaces to control just 8-24 electrodes. The next generation of neural prostheses will require substantial advances in both enabling technologies and systems design.

#### V. REFERENCES

- [1] W.B. Marks, G.E. Loeb, “Action currents, intermodal potentials, and extracellular records of myelinated mammalian nerve fibers derived from node potentials,” *Biophys. J.*, Vol. 16, pp. 655-668, 1976.
- [2] W. Rall, “Electrophysiology of a dendritic neuron model,” *Biophys. J.*, Vol. 2, pp. 145-167, 1962.
- [3] J.C. Williams, R.L. Rennaker, D.R. Kipke, “Stability of chronic multichannel neural recordings: Implications for a long-term neural interface,” *Neurocomputing*, Vol. 26-27, pp. 1069-1076, 1999.
- [4] J.B. Ranck, Jr., “Which elements are excited in electrical stimulation of mammalian central nervous system: A review,” *Brain Res.*, Vol. 98, pp. 417-440, 1975.
- [5] S.B. Brummer, L.S. Robblee, F.T. Hambrecht, “Criteria for selecting electrodes for electrical stimulation: Theoretical and practical considerations,” *Ann. NY Acad. Sci.*, Vol. 405, pp. 159-171, 1983.
- [6] G.E. Loeb, J. McHardy, E.M. Kelliher, S.B. Brummer, “Neural Prosthesis,” IN: *Biocompatibility in Clinical Practice*, Vol. II (Ed. D.F. Williams), CRC Press, Boca Raton, 1982, pp. 123-149.
- [7] W.J. Heetderks, “RF powering of millimeter- and submillimeter-sized neural prosthetic implants,” *IEEE Trans. Biomed. Engng.*, Vol. 35, pp. 323-327, 1988.
- [8] G.E. Loeb and J.D. Wills, “Charge-metered biomedical stimulator,” US Patent Appl. #20060004424, Jan. 5, 2006.
- [9] Xang Fang, J. Wills, J. LaCoss, A. Arakelian, J. Weiland, “Novel charge-metering stimulus amplifier for biomimetic implantable prosthesis,” *IEEE Int. Symp. Circuits and Systems 2007*, pp 569-572.
- [10] B.D. Ratner, S.J. Bryant, “Biomaterials: where we have been and where we are going,” *Ann. Rev. Biomed. Engng.*, Vol.6, pp. 41-75, 2004.